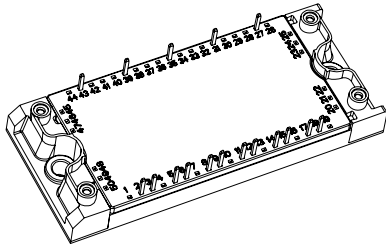

## IGBT Sixpack Module, 48 A

**ECONO2 6PACK**

PRODUCT SUMMARY	
$V_{CES}$	600 V
$V_{CE(on)}$ (typical)	1.89 V
$t_{sc}$ at $T_J = 150\text{ }^\circ\text{C}$	> 10 $\mu\text{s}$
$I_C$ at $T_C = 80\text{ }^\circ\text{C}$	48 A

### FEATURES

- Low diode  $V_F$
- 10  $\mu\text{s}$  short circuit capability
- Square RBSOA
- Low  $V_{CE(on)}$  non punch through IGBT technology
- HEXFRED<sup>®</sup> antiparallel diode with ultrasoft reverse recovery characteristics
- Positive  $V_{CE(on)}$  temperature coefficient
- Ceramic DBC substrate
- Low stray inductance design
- Speed 8 to 60 kHz
- Totally lead (Pb)-free
- Designed and qualified for industrial market

**RoHS**  
COMPLIANT

### BENEFITS

- Benchmark efficiency for motor control
- Rugged transient performance
- Low EMI, requires less snubbing
- Direct mounting to heatsink
- PCB solderable terminals
- Low junction to case thermal resistance

ABSOLUTE MAXIMUM RATINGS				
PARAMETER	SYMBOL	TEST CONDITIONS	MAX.	UNITS
Collector to emitter voltage	$V_{CES}$		600	V
Continuous collector current	$I_C$	$T_C = 25\text{ }^\circ\text{C}$	80	A
		$T_C = 80\text{ }^\circ\text{C}$	48	
Pulsed collector current See fig. C.T.5	$I_{CM}$		160	
Clamped inductive load current	$I_{LM}$		160	
Diode continuous forward current	$I_F$	$T_C = 25\text{ }^\circ\text{C}$	80	
		$T_C = 80\text{ }^\circ\text{C}$	48	
Diode maximum forward current	$I_{FM}$		160	
Gate to emitter voltage	$V_{GE}$		$\pm 20$	V
Maximum power dissipation (IGBT and Diode)	$P_D$	$T_C = 25\text{ }^\circ\text{C}$	315	W
		$T_C = 80\text{ }^\circ\text{C}$	177	
Maximum operating junction temperature	$T_J$		150	$^\circ\text{C}$
Storage temperature range	$T_{Stg}$		- 40 to + 125	
Isolation voltage	$V_{ISOL}$		AC 2500 (minimum)	V



<b>ELECTRICAL SPECIFICATIONS</b> ( $T_J = 25\text{ }^\circ\text{C}$ unless otherwise specified)						
PARAMETER	SYMBOL	TEST CONDITIONS	MIN.	TYP.	MAX.	UNITS
Collector to emitter breakdown voltage	$BV_{(CES)}$	$V_{GE} = 0\text{ V}, I_C = 500\text{ }\mu\text{A}$	600	-	-	V
Temperature coefficient of breakdown voltage	$\Delta V_{(BR)CES}/\Delta T_J$	$V_{GE} = 0\text{ V}, I_C = 1\text{ mA}$ (25 °C to 125 °C)	-	0.73	-	V/°C
Collector to emitter voltage	$V_{CE(ON)}$	$I_C = 50\text{ A}, V_{GE} = 15\text{ V}$	-	1.89	2.30	V
		$I_C = 100\text{ A}, V_{GE} = 15\text{ V}$	-	2.56	3.24	
		$I_C = 50\text{ A}, V_{GE} = 15\text{ V}, T_J = 125\text{ }^\circ\text{C}$	-	2.17	2.65	
		$I_C = 100\text{ A}, V_{GE} = 15\text{ V}, T_J = 125\text{ }^\circ\text{C}$	-	3.05	3.93	
Gate threshold voltage	$V_{GE(th)}$	$V_{CE} = V_{GE}, I_C = 250\text{ }\mu\text{A}$	3.5	-	5.5	
Threshold voltage temperature coefficient	$\Delta V_{GE(th)}/\Delta T_J$	$V_{CE} = V_{GE}, I_C = 1\text{ mA}$ (25 °C to 125 °C)	-	- 11	-	mV/°C
Zero gate voltage collector current	$I_{CES}$	$V_{GE} = 0\text{ V}, V_{CE} = 600\text{ V}$	-	-	100	$\mu\text{A}$
		$V_{GE} = 0\text{ V}, V_{CE} = 600\text{ V}, T_J = 125\text{ }^\circ\text{C}$	-	750	-	
Diode forward voltage drop	$V_{FM}$	$I_F = 50\text{ A}$	-	1.34	1.68	V
		$I_F = 100\text{ A}$	-	1.62	2.19	
		$I_F = 50\text{ A}, T_J = 125\text{ }^\circ\text{C}$	-	1.31	1.77	
		$I_F = 100\text{ A}, T_J = 125\text{ }^\circ\text{C}$	-	1.65	2.43	
Gate to emitter leakage current	$I_{GES}$	$V_{GE} = \pm 20\text{ V}$	-	-	100	nA

<b>SWITCHING CHARACTERISTICS</b> ( $T_J = 25\text{ }^\circ\text{C}$ unless otherwise noted)						
PARAMETER	SYMBOL	TEST CONDITIONS	MIN.	TYP.	MAX.	UNITS
Total gate charge (turn-on)	$Q_G$	$I_C = 50\text{ A}$ $V_{CC} = 460\text{ V}$ $V_{GE} = 15\text{ V}$	-	175	263	nC
Gate to emitter charge (turn-on)	$Q_{GE}$		-	22	33	
Gate to collector charge (turn-on)	$Q_{GC}$		-	86	129	
Turn-on switching loss	$E_{on}$	$I_C = 50\text{ A}, V_{CC} = 300\text{ V}$ $V_{GE} = 15\text{ V}, R_G = 10\text{ }\Omega, L = 200\text{ }\mu\text{H}$ $T_J = 25\text{ }^\circ\text{C}$ (1)	-	0.25	0.38	mJ
Turn-off switching loss	$E_{off}$		-	0.55	0.83	
Total switching loss	$E_{tot}$		-	0.80	1.21	
Turn-on switching loss	$E_{on}$	$I_C = 50\text{ A}, V_{CC} = 300\text{ V}$ $V_{GE} = 15\text{ V}, R_G = 10\text{ }\Omega, L = 200\text{ }\mu\text{H}$ $T_J = 125\text{ }^\circ\text{C}$ (1)	-	0.39	0.58	mJ
Turn-off switching loss	$E_{off}$		-	0.82	1.23	
Total switching loss	$E_{tot}$		-	1.21	1.81	
Turn-on delay time	$t_{d(ON)}$	$I_C = 50\text{ A}, V_{CC} = 300\text{ V}$ $V_{GE} = 15\text{ V}, R_G = 10\text{ }\Omega, L = 200\text{ }\mu\text{H}$ $T_J = 125\text{ }^\circ\text{C}$	-	139	209	ns
Rise time	$t_r$		-	33	50	
Turn-off delay time	$t_{d(OFF)}$		-	164	246	
Fall time	$t_f$		-	84	126	
Input capacitance	$C_{ies}$	$V_{GE} = 0\text{ V}$ $V_{CC} = 30\text{ V}$ $f = 1\text{ MHz}$	-	3016	-	pF
Output capacitance	$C_{oes}$		-	742	-	
Reverse transfer capacitance	$C_{res}$		-	103	-	
Reverse bias safe operating area	RBSOA	$T_J = 150\text{ }^\circ\text{C}, I_C = 120\text{ A}$ $R_G = 47\text{ }\Omega, V_{GE} = 15\text{ V to } 0\text{ V}$	Fullsquare			
Short circuit safe operating area	SCSOA	$V_{CC} = 300\text{ V},$ $I_P = 370\text{ A to } 530\text{ A}$ $R_G = 47\text{ }\Omega, V_{GE} = 15\text{ V to } 0\text{ V}$	10	-	-	$\mu\text{s}$
Diode peak reverse recovery current	$I_{rr}$	$T_J = 125\text{ }^\circ\text{C}$ $V_{CC} = 300\text{ V}, I_F = 10\text{ A}$	-	67	-	A

**Note**

(1) Energy losses include "tail" and diode reverse recovery



THERMAL AND MECHANICAL SPECIFICATIONS					
PARAMETER	SYMBOL	MIN.	TYP.	MAX.	UNITS
Junction to case IGBT	R <sub>thJC</sub>	-	-	0.58	°C/W
Junction to case DIODE		-	-	1.25	
Case to sink, flat, greased surface	R <sub>thCS</sub>	-	0.05	-	
Mounting torque (M5)		2.7	-	3.3	Nm
Weight		-	170	-	g

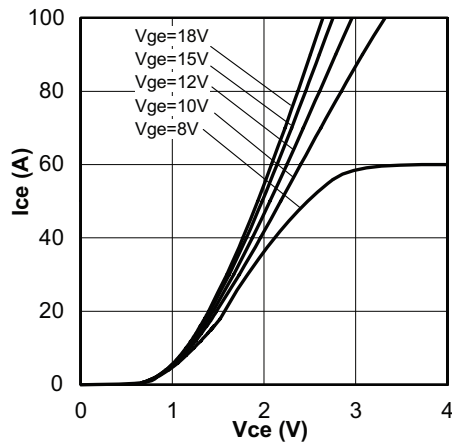

Fig. 1 - Typical IGBT Output Characteristics  
T<sub>J</sub> = 25 °C; t<sub>p</sub> = 80 μs

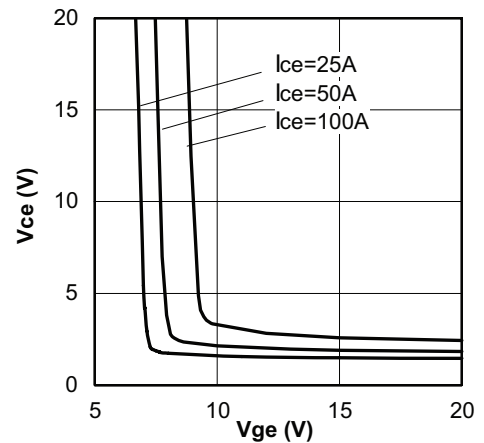

Fig. 3 - Typical V<sub>CE</sub> vs. V<sub>GE</sub>  
T<sub>J</sub> = 25 °C

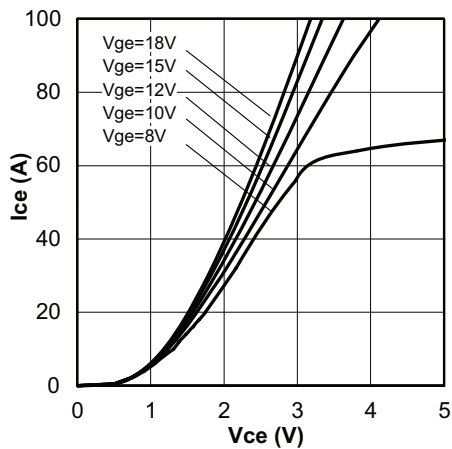

Fig. 2 - Typical IGBT Output Characteristics  
T<sub>J</sub> = 125 °C, t<sub>p</sub> = 80 μs

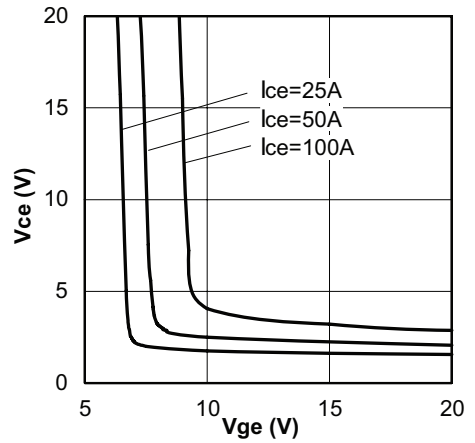

Fig. 4 - Typical V<sub>CE</sub> vs. V<sub>GE</sub>  
T<sub>J</sub> = 125 °C

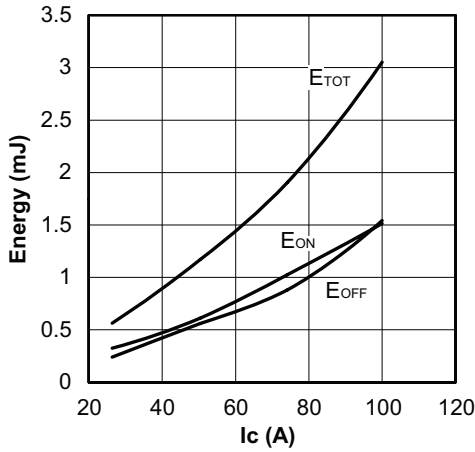

Fig. 5 - Typical Energy Loss vs.  $I_C$   
 $T_J = 125\text{ }^\circ\text{C}$ ;  $L = 200\text{ }\mu\text{H}$ ;  $V_{CE} = 300\text{ V}$ ,  
 $R_G = 22\text{ }\Omega$ ;  $V_{GE} = 15\text{ V}$

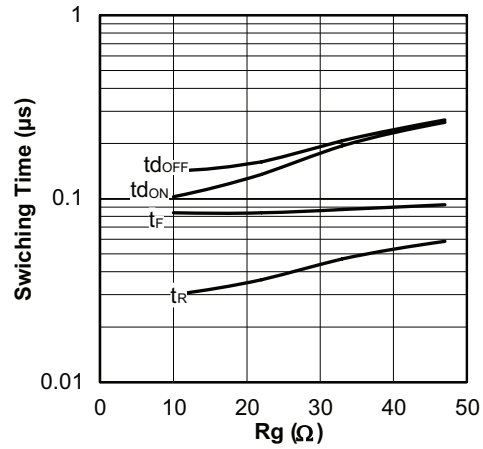

Fig. 8 - Typical Switching Time vs.  $R_G$   
 $T_J = 125\text{ }^\circ\text{C}$ ;  $L = 200\text{ }\mu\text{H}$ ;  $V_{CE} = 300\text{ V}$   
 $I_{CE} = 50\text{ A}$ ;  $V_{GE} = 15\text{ V}$

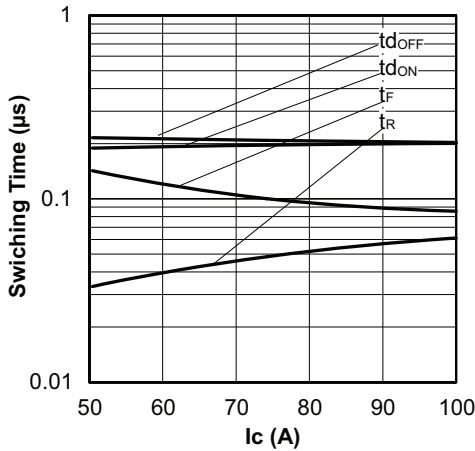

Fig. 6 - Typical Switching Time vs.  $I_C$   
 $T_J = 125\text{ }^\circ\text{C}$ ;  $L = 200\text{ }\mu\text{H}$ ;  $V_{CE} = 300\text{ V}$ ,  
 $R_G = 22\text{ }\Omega$ ;  $V_{GE} = 15\text{ V}$

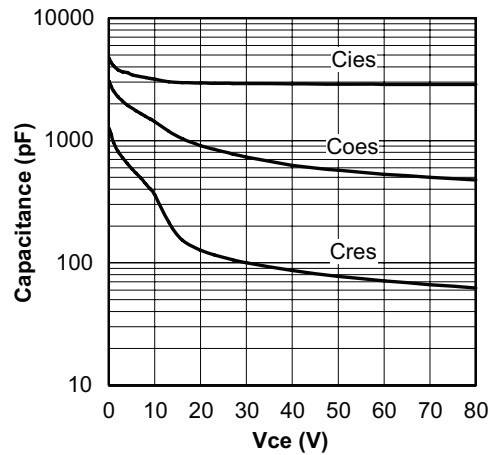

Fig. 9 - Typical Capacitance vs.  $V_{CE}$   
 $V_{GE} = 0\text{ V}$ ;  $f = 1\text{ MHz}$

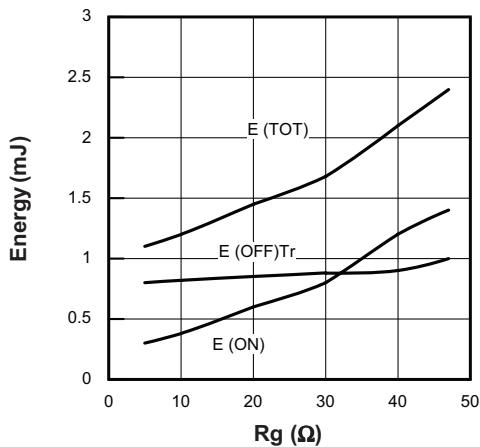

Fig. 7 - Typical Energy Loss vs.  $R_G$   
 $T_J = 125\text{ }^\circ\text{C}$ ;  $L = 200\text{ }\mu\text{H}$ ;  $V_{CE} = 300\text{ V}$   
 $I_{CE} = 50\text{ A}$ ;  $V_{GE} = 15\text{ V}$

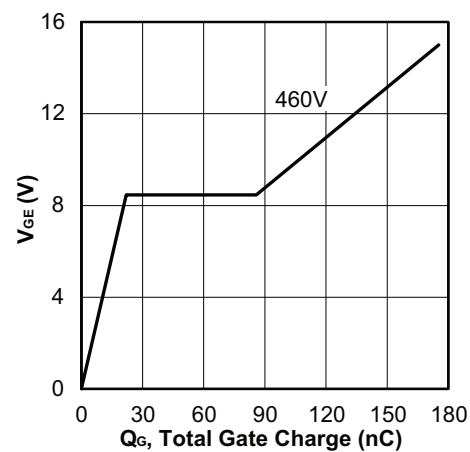

Fig. 10 - Typical Gate Charge vs.  $V_{GE}$   
 $I_{CE} = 50\text{ A}$

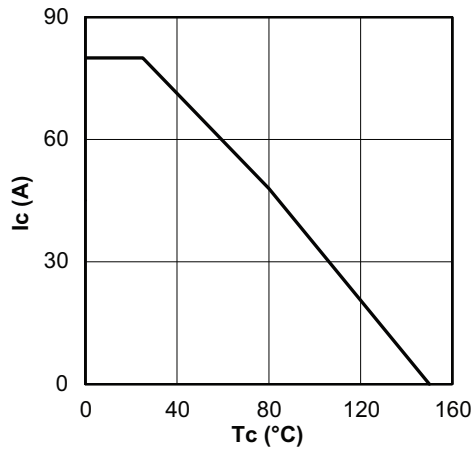

Fig. 11 - Maximum DC Collector Current vs. Case Temperature

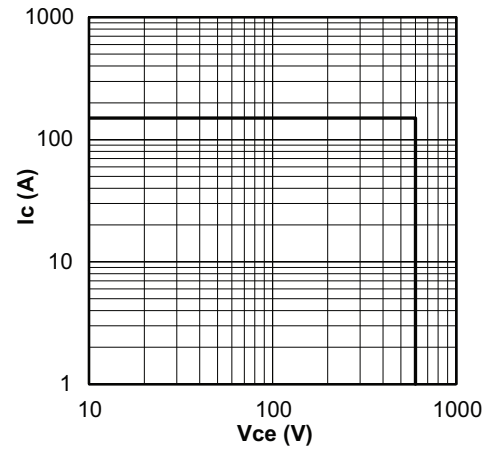

Fig. 14 - Reverse Bias SOA  
 $T_J = 150^\circ\text{C}$ ;  $V_{GE} = 15\text{ V}$

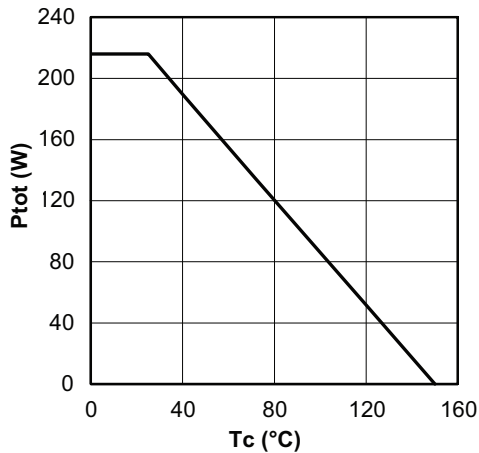

Fig. 12 - Power Dissipation vs. Case Temperature (IGBT only)

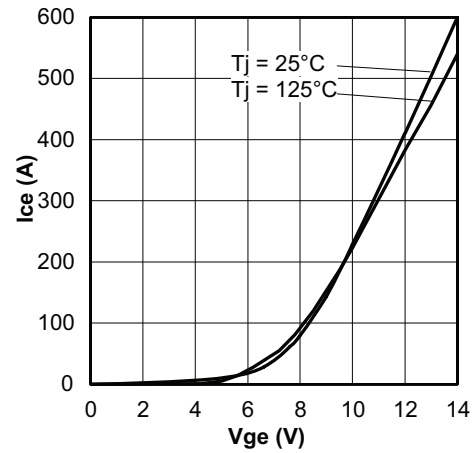

Fig. 15 - Typical Transfer Characteristics  
 $V_{CE} = 50\text{ V}$ ;  $t_p = 10\ \mu\text{s}$

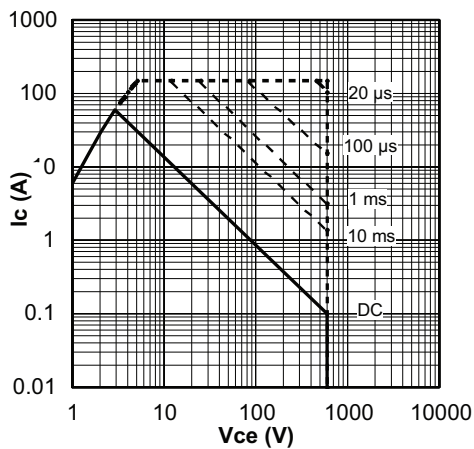

Fig. 13 - Forward SOA  
 $T_C = 25^\circ\text{C}$ ;  $T_J \leq 150^\circ\text{C}$

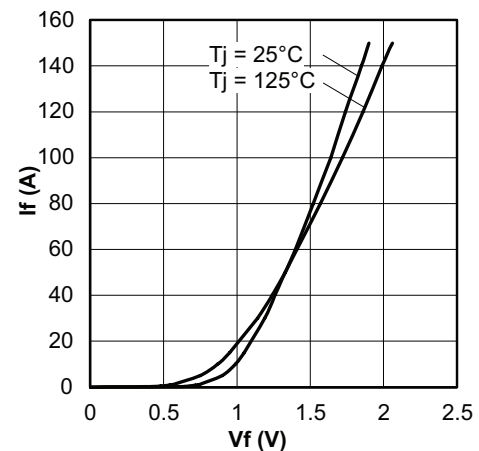

Fig. 16 - Typical Diode Forward Characteristics  
 $t_p = 80\ \mu\text{s}$

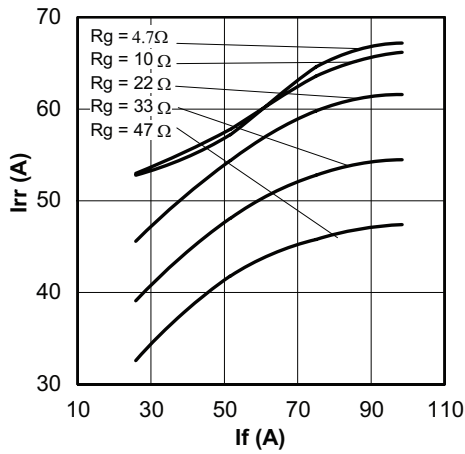

Fig. 17 - Typical Diode  $I_{RR}$  vs.  $I_F$   
 $T_J = 125^\circ\text{C}$

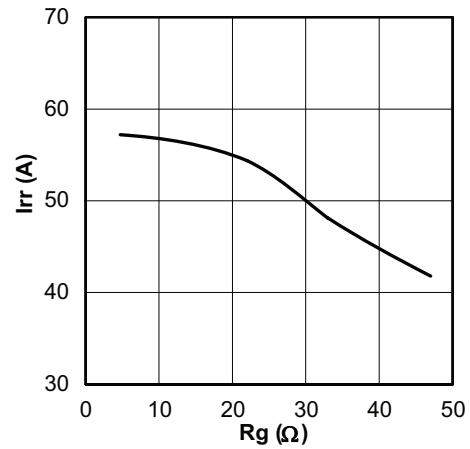

Fig. 18 - Typical Diode  $I_{RR}$  vs.  $R_G$   
 $T_J = 125^\circ\text{C}$ ;  $I_F = 10\text{ A}$

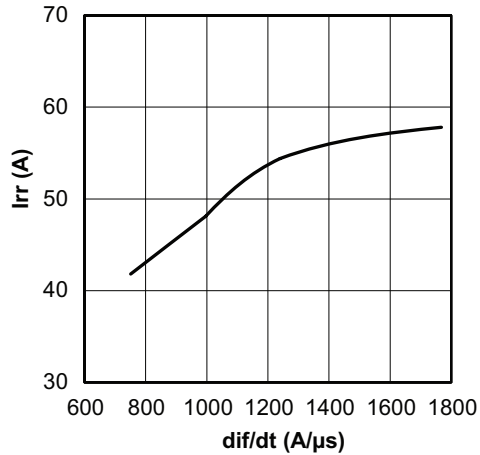

Fig. 19 - Typical Diode  $I_{RR}$  vs.  $dI_F/dt$ ;  $V_{CC} = 300\text{ V}$ ;  
 $V_{GE} = 15\text{ V}$ ;  $I_{CE} = 50\text{ A}$ ;  $T_J = 125^\circ\text{C}$

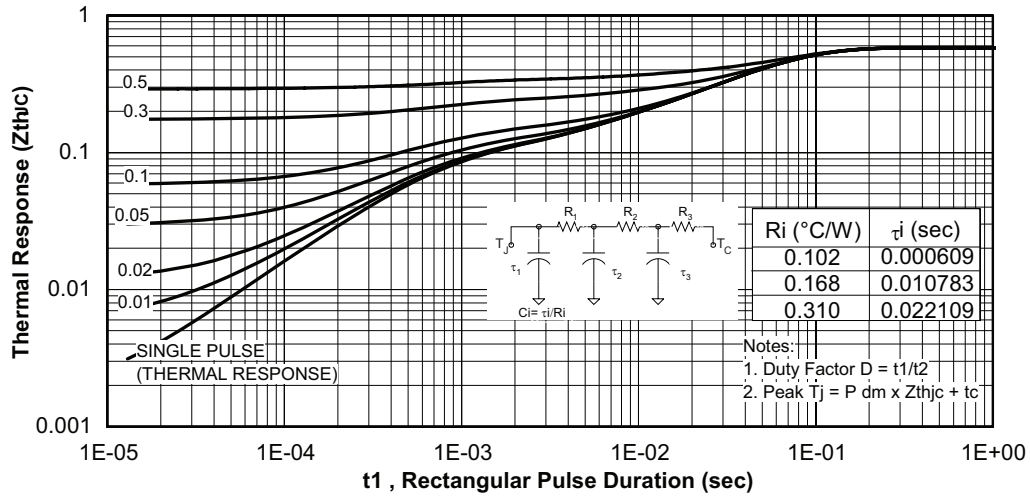

Fig. 20 - Maximum Transient Thermal Impedance, Junction to Case (IGBT)

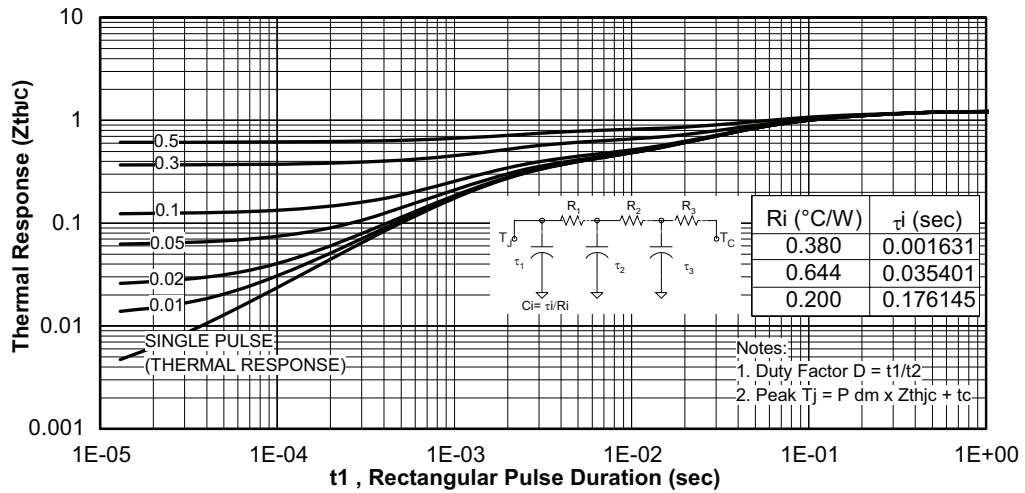

Fig. 21 - Maximum Transient Thermal Impedance, Junction to Case (DIODE)

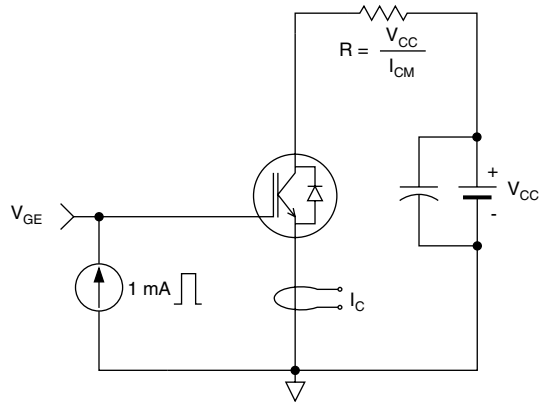

Fig. C.T.1 - Gate Charge Circuit (Turn-Off)

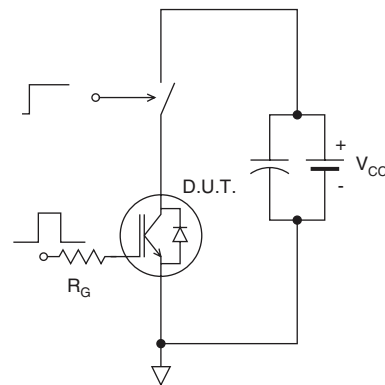

Fig. C.T.3 - S.C. SOA Circuit

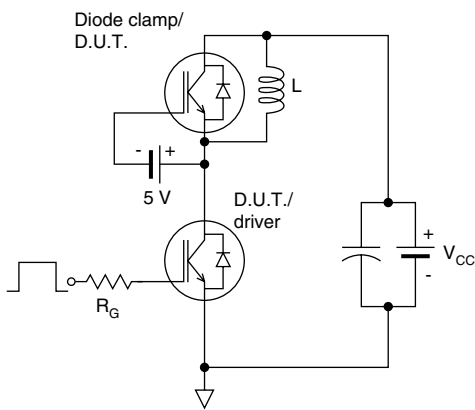

Fig. C.T.2 - RB SOA Circuit

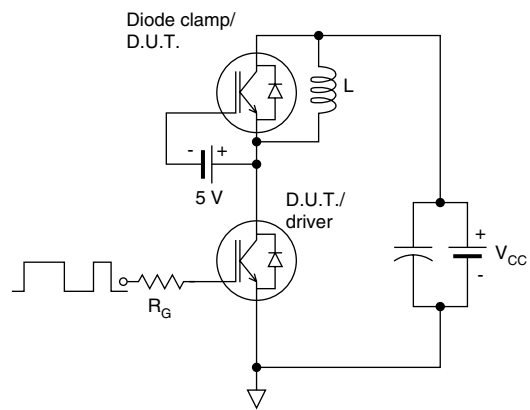

Fig. C.T.4 - Switching Loss Circuit

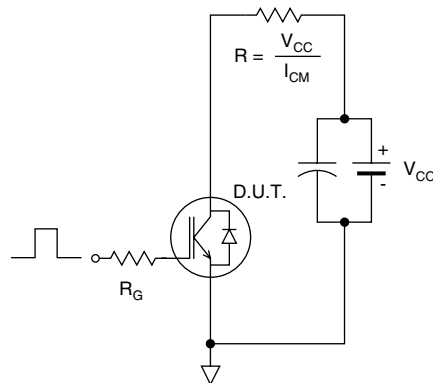

Fig. C.T.5 - Resistive Load Circuit



**ORDERING INFORMATION TABLE**

Device code	<b>G</b>	<b>B</b>	<b>50</b>	<b>X</b>	<b>F</b>	<b>60</b>	<b>K</b>
	①	②	③	④	⑤	⑥	⑦

- 1** - Insulated Gate Bipolar Transistor (IGBT)
- 2** - B = IGBT Generation 5 NPT
- 3** - Current rating (50 = 50 A)
- 4** - Circuit configuration (X = Sixpack or three phase inverter)
- 5** - Package indicator (F = ECONO2)
- 6** - Voltage rating (60 = 600 V)
- 7** - Speed/type (K = Ultrafast IGBT/Speed 8 to 60 kHz)

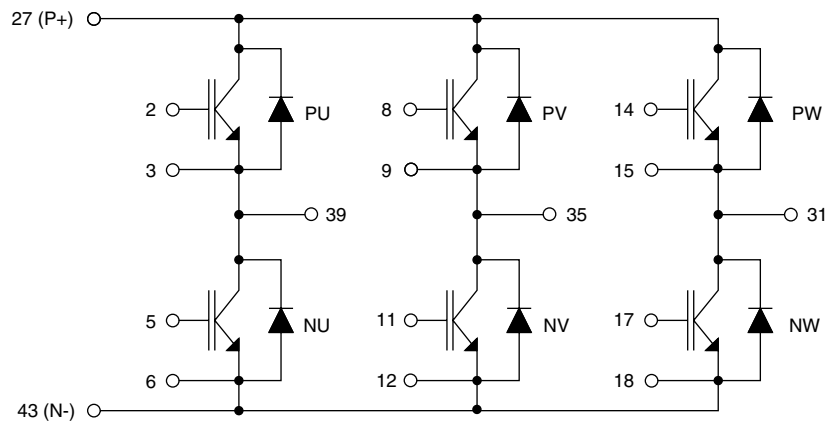
**CIRCUIT CONFIGURATION**

LINKS TO RELATED DOCUMENTS	
Dimensions	<a href="http://www.vishay.com/doc?95089">http://www.vishay.com/doc?95089</a>
Part marking information	<a href="http://www.vishay.com/doc?95090">http://www.vishay.com/doc?95090</a>



## Disclaimer

All product specifications and data are subject to change without notice.

Vishay Intertechnology, Inc., its affiliates, agents, and employees, and all persons acting on its or their behalf (collectively, "Vishay"), disclaim any and all liability for any errors, inaccuracies or incompleteness contained herein or in any other disclosure relating to any product.

Vishay disclaims any and all liability arising out of the use or application of any product described herein or of any information provided herein to the maximum extent permitted by law. The product specifications do not expand or otherwise modify Vishay's terms and conditions of purchase, including but not limited to the warranty expressed therein, which apply to these products.

No license, express or implied, by estoppel or otherwise, to any intellectual property rights is granted by this document or by any conduct of Vishay.

The products shown herein are not designed for use in medical, life-saving, or life-sustaining applications unless otherwise expressly indicated. Customers using or selling Vishay products not expressly indicated for use in such applications do so entirely at their own risk and agree to fully indemnify Vishay for any damages arising or resulting from such use or sale. Please contact authorized Vishay personnel to obtain written terms and conditions regarding products designed for such applications.

Product names and markings noted herein may be trademarks of their respective owners.